

Analyst's Notebook 7

- Shortcuts, Hints & Tips

Function	Shortcut
New standard chart	Ctrl+N
New from template	Ctrl+Shift+N
Open chart	Ctrl+O
Print chart	Ctrl+P
Save chart	Ctrl+S
Minimize current window	Ctrl+F9
Close current chart	Ctrl+F4
Exit Analyst's Notebook	Alt+F4
Check spelling	F7
Select All	Ctrl+A
Copy selection to clipboard	Ctrl+C (nb: If Timebar is present, it will copy too)
Cut selection to clipboard	Ctrl+X
Paste from clipboard	Ctrl+V



Analyst Notebook General Functions

Function	Shortcut
Duplicate selection	Ctrl+D
Full Screen mode	F8
Zoom in on chart	Page Up
Zoom out on chart	Page Down
Pan / Move chart window to the right	Right arrow
Pan / Move chart window to the left	Left arrow
Pan / Move chart window upwards	Up arrow
Pan / Move chart window downwards	Down arrow
Fit entire chart in window	End
Fit height of chart in window	Shift+End
Fit selection in window	Ctrl+End
View chart or items selected at actual size	Home
Next snapshot	Ctrl+T
Previous snapshot	Ctrl+Shift+T

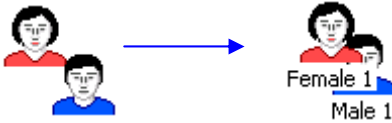

Searching

Function	Shortcut
Find Text	F4, Ctrl+F, Edit - Find Text
Find Next Text	F3
Visual Search	F5, Analysis - Visual Search
List Items	F11, Analysis - List Items

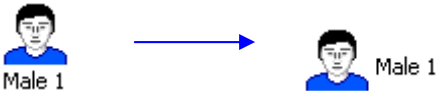
Icons:

Function	Shortcut
Add multiple icons (same type) to the chart 	1) Select icon type first 2) Hold Shift key down while placing icons on the chart. 3) Press Esc key when done.
Choose multiple icons from icon palette bar to place on chart at same time 	1) Hold the Shift key down while selecting icons from palette bar. 2) Left click on mouse button to add to the chart. 3) Click in the white space of the icon palette to deselect multiples.
Change icon type automatically to another icon type. Eg from male to female. 	1) Select new icon type 2) Left mouse click and drag the new icon over the icon to be replaced until the swap over image  appears at the bottom right hand corner. 3) Release the mouse button.
Move label of icon 	1) Hold Alt key down. 2) Left mouse click on label & move. 3) Release mouse button when done. To restore default, press Alt key down and double click on label.

Links:

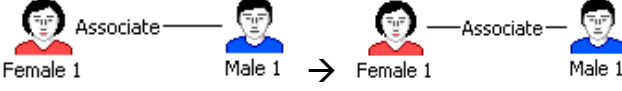
Function	Shortcut
Add multiple links (same type) to the chart	1) First select link type from palette. 2) Hold Shift key down while linking. 3) Press Esc key when done.
Automatically add arrow head to the link 	1) Select link type from palette. 2) Hold Ctrl key down while linking or use right mouse & drag to create link and choose Link with arrow from shortlist.
Add multiple links with arrow heads	1) Select link type from palette. 2) Hold Shift+Ctrl keys down simultaneously while linking or use right mouse to create link. 3) Press Esc key when done.
Separate multiple links 	1) Hold Shift keys down. 2) Left click on the link label and pull links apart.
Move link label 	1) Hold Alt key down. 2) Left mouse click on label & move. 3) Release mouse button when done. To restore default, press Alt key down and double click on label

Themelines & Event Frames:

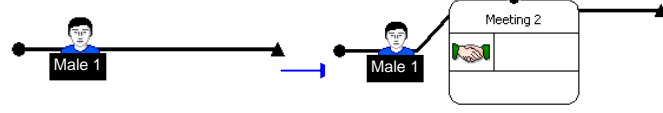
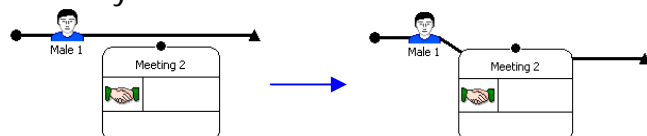
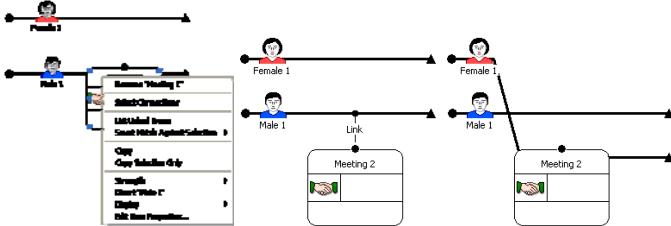
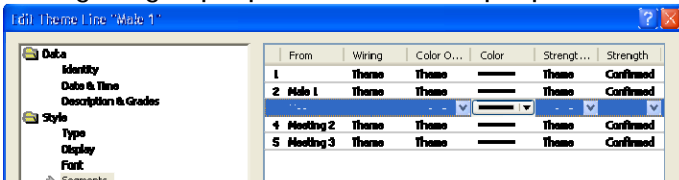
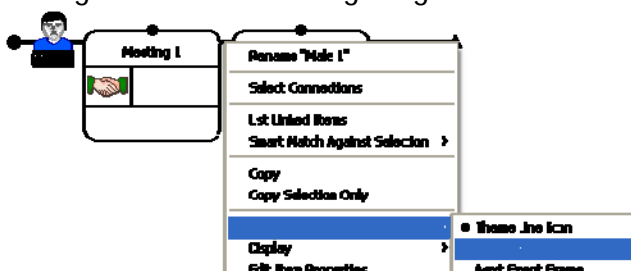
Function	Shortcut
<p>Change Representation from icon to themeline or event frame or box, etc..</p> 	<ol style="list-style-type: none"> 1) Select icon. 2) Tools - Change Representation. 3) Select new representation (icon, box, circle, themeline, ...).
<p>Add event frame automatically to themeline(s).</p> 	<p>Fully-Automatic Linking:</p> <ol style="list-style-type: none"> 1) Select themeline(s) first. 2) Select link type next. 3) Select Event Frame from palette. 4) Hold Ctrl & left click on the chart. <p>Sem-Automatic Linking:</p> <ol style="list-style-type: none"> 1) Do not select themeline. 2) Select link type next. 3) Select Event Frame from palette. 4) Hold Ctrl & hover over themeline and left click when + seen.
<p>Manually link an event frame to a themeline.</p> 	<ol style="list-style-type: none"> 1) Select link type from palette. 2) Create link from themeline to event frame. <p>Default chart properties will automatically divert the themeline.</p>
<p>Move Event Frame from one themeline to another themeline. (eg. If event frame was mistakenly placed on the wrong themeline).</p> 	<ol style="list-style-type: none"> 1) Right click on event frame. 2) Unselect Divert <Themeline's identity>. 3) Move Event Frame so link is visible. 4) Delete the link (Select link and press DEL key). 5) Select link type from link palette. 6) Create new link from event frame to the themeline.
<p>Change themeline segment colour, strength or wiring height properties via item properties.</p> 	<ol style="list-style-type: none"> 1) Double click on the themeline segment. 2) Go to Style - Segments. 3) Change colour, strength or wiring height. 4) Click OK when done.
<p>Change themeline wiring height</p> 	<ol style="list-style-type: none"> 1) Right click on the segment of the themeline you wish to change. 2) Select Wiring Height. 3) Select appropriate Wiring Height: <ul style="list-style-type: none"> • Theme Line Icon • Previous Event Frame • Next Event Frame

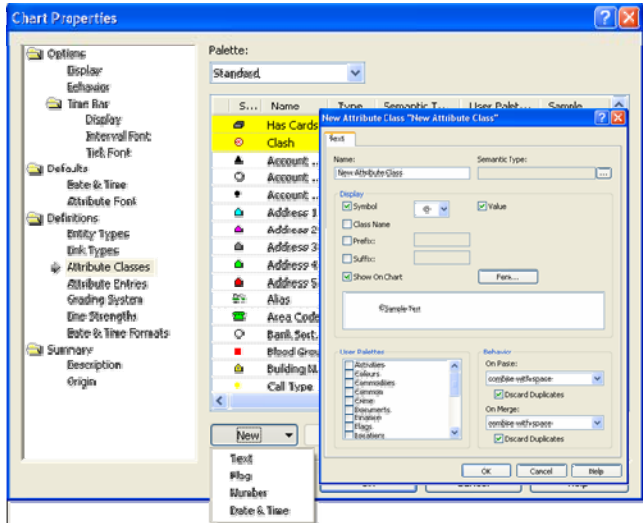
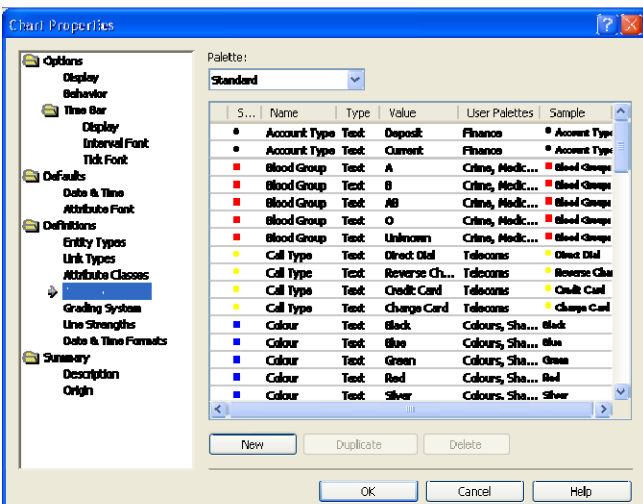
Function	Shortcut
<p>Edit or create new Attribute Classes</p> 	<ol style="list-style-type: none"> 1) Right click in white space of Attribute Entries area - Edit Attribute Classes, or; 2) Right click in white space of chart. Edit Chart Properties - Definitions - Attribute Classes, or; 3) File - Chart Properties - Definitions - Attribute Classes.
<p>Edit or create new Attribute Entries</p> 	<ol style="list-style-type: none"> 1) Right click in white space of Attribute Entries area - Edit Attribute Entries, or; 2) Right click in white space of chart. Edit Chart Properties - Definitions - Attribute Entries, or; 3) File - Chart Properties - Definitions - Attribute Entries.

Assigning icons to palettes:

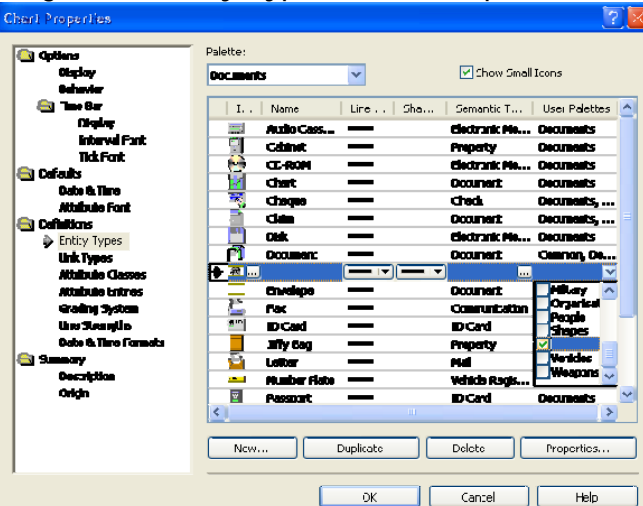
Function	Shortcut
<p>Assign new Entity Types (icons) to palettes</p> 	<ol style="list-style-type: none"> 1) Right click in white space of chart. Edit Chart Properties - Definitions - Entity Types, or; 2) Right click in white space of icon palette area. Edit Entity Types, or; 3) File - Chart Properties - Definitions - Entity Types.

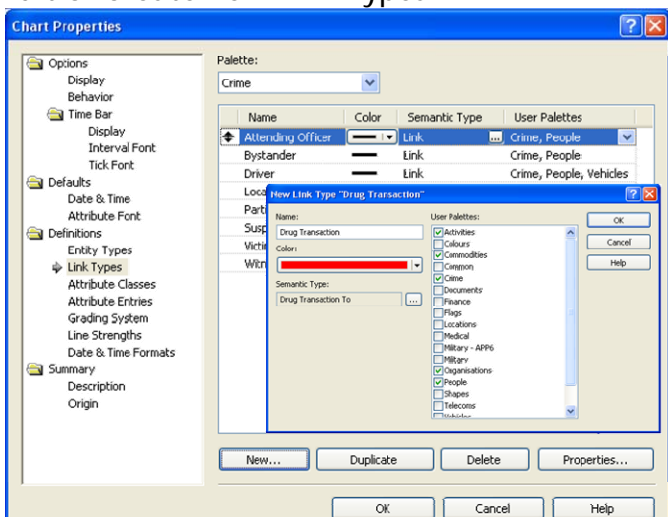
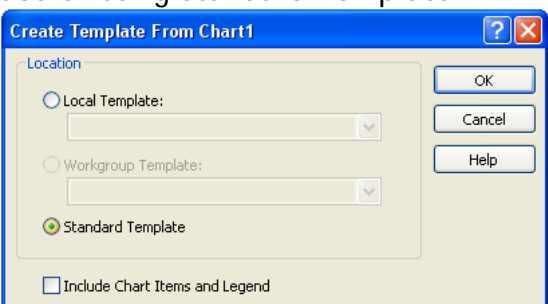
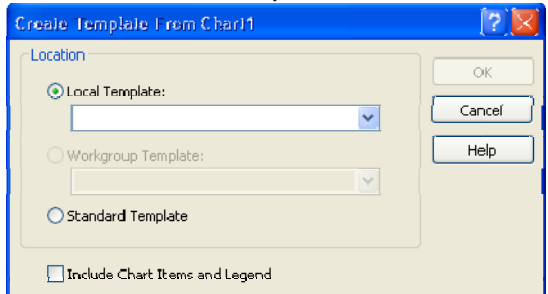
Function	Shortcut
<p>Create your own entity icons</p>  <p>Icons all reside on the C:\ drive at the following locations:</p> <p>C:\Program Files\Common Files\i2 Shared\Images 7\Basic\Screen\Icons</p> <p>C:\Program Files\Common Files\i2 Shared\Images 7\Basic\Printer\Icons</p> <p>To print, icons must appear in the printer folder as well as the screen folder.</p> <p><i>New icons must then be added to palettes.</i></p>	<p>Open Windows Explorer. Search on the C:\ drive for an icon that already exists (eg: cow.bmp) - these are bitmap files (*.bmp). Alternatively, go to the file location (see left). Make a copy of the file and edit the new file to the figure you require. <i>Do not make the picture larger. Do not change the background fuchsia colour (used to represent transparency in AN).</i> <i>Restart AN7 for icons to be available for palettes.</i></p>
<p>Edit or create new Link Types</p> 	<ol style="list-style-type: none"> 1) Right click in white space of chart. Edit Chart Properties - Definitions - Link Types, or; 2) File - Chart Properties - Definitions - Link Types.
<p>Replace existing Standard Template</p> 	<ol style="list-style-type: none"> 1) File - Create Template 2) Select Standard Template (Optional: include chart items and legends). 3) Click OK. 4) Dialogue box will prompt you asking if you want to replace existing template. Choose Yes.
<p>Create a new local template</p> 	<ol style="list-style-type: none"> 1) File - Create Template 2) Select Local Template. Enter name of new template. (Optional: include chart items and legends). 3) Click OK.